



La Rinconada
Town Hall

Line 2: Reducing Energy Consumption

“Installation of Photovoltaic Panels on the Roof of the Nuestra Señora del Patrocinio (PÚA) School”

La Rinconada Town Hall

1. INTRODUCTION – SUMMARY

ERDF funds are greatly contributing to La Rinconada (Seville) municipality’s urban development. One of the most significant lines within this strategy is “Reducing Energy Consumption”.

Among the various initiatives developed, the “Installation of Photovoltaic Panels on the Roof of the Nuestra Señora del Patrocinio (PÚA) School” stands out.

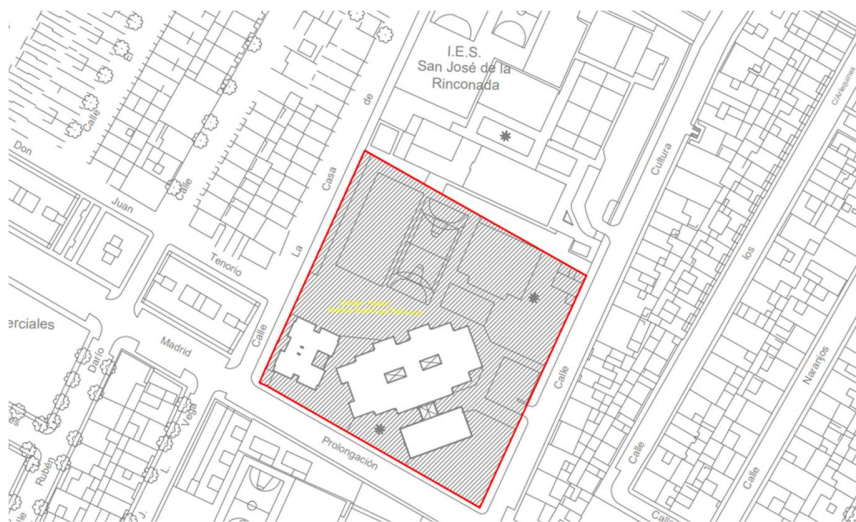

This project, which coincides with the 50th anniversary of the educational centre, involved installing photovoltaic panels on the roof of the PÚA. The aim is to harness renewable energy to reduce both the emission of polluting gases into the atmosphere and the electricity bill. This initiative is part of one of the strategic lines of “La Rinconada, Ciudad Única” project, which aims to transform La Rinconada into a Smart City.

The project falls within the municipal competencies, specifically the maintenance and conservation of municipally owned schools. It will achieve significant energy savings, reducing electricity consumption and CO₂ emissions, while architecturally integrating the photovoltaic system into the roof, minimising visual impact and ensuring good performance.



La Rinconada
Town Hall

2. CHARGES

The total investment for this programme amounts to €65,128.26, of which 80 % is funded by ERDF funds, while the remaining 20 % comes from La Rinconada Town Hall's own funds. Moreover, the total VAT (€11,303.25) is entirely financed by La Rinconada Town Hall. The programme impact is reflected on the Sustainable and Integrated Urban Development (EDUSI), reducing energy consumption, the emission of polluting gases, and the electricity bill.

Description of the Item	Amount € (without VAT)	% VAT	Amount € (with VAT)
Photovoltaic Equipment	31,210.31 €	21%	37,764.48 €
Electrical Installation	3,669.09 €	21%	4,439.60 €
Labour	4,453.15 €	21%	5,388.31 €
Machinery Rental	491.51 €	21%	594.73 €
Safety and Health	4,333.39 €	21%	5,243.40 €
Waste Management	159.53	21%	193.03 €
Quality Control	825.05 €	21%	998.31 €
Total Material Execution	45,142.03 €		54,621.86 €
6% Industrial Profit	2,708.52 €	21%	3,277.31 €
13% General Expenses	5,868.46 €	21%	7,100.84 €
Communication Measures	106.00 €	21%	128.26 €
TOTAL	53,825.01 €		65,128.26 €

3. PHOTOVOLTAIC PANELS

The installation, designed according to the technical specifications, has the following characteristics:

- The installation will have a rated power of 35,49 kWp.
- It is planned to install 80 panels of 455 W on the roof of the pre-primary school, with an inclination of 10°.
- A 36 kW inverter will be used.



La Rinconada
Town Hall

One group of modules will be installed, which will be grouped into 4 strings, each consisting of 20 modules. The municipal electricity supplier is ENDESA DISTRIBUCIÓN ELÉCTRICA S.L.U., and the supply voltage is 400V.

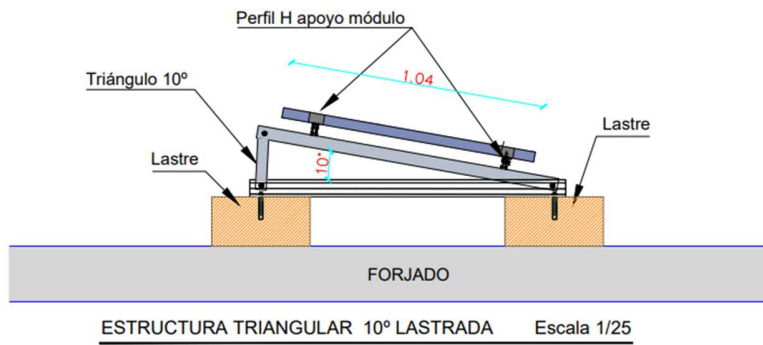

Magnitude	STC	NOCT
Brand	TRINASOLAR	
Model	TALLMAX 144 LAYOUT MODULE	
Rated Power (Wp)	455	344
Voltage at Pmax-VMPP (V)	41.2	38.9
Current at Pmax-IMPP (A)	11.06	8.84
Open Circuit Voltage Voc (V)	49.8	46.8
Short Circuit Current (A)	11.68	9.41
Module Efficiency (%)	20.8	
Maximum System Voltage (V)	1,500 VDC (IEC)	
Maximum Fuse Values (A)	20	
Operational Temperature (°C)	-40÷+85	
Coeficiente de Temperatura Pmax (%/°C)	-0.34	
Temperature Coefficient Voc (%/°C)	-0.25	
Temperature Coefficient Isc (%/°C)	0.04	



La Rinconada
Town Hall

Nominal Operational Temperature (°C)	43 ± 2
Cell Type	Monocrystalline
Number of Cells	144
Dimensions	2102x1040x35 mm
Weight	24.0 kg

4. ENERGY ANALYSIS

Considering the energy generated from the proposed photovoltaic system and the electricity billing provided by La Rinconada Town Hall, the potential energy savings for the Sra. del Patrocinio School building have been calculated as follows:

Parameter	Value	Units
Energy Savings	26,125	kWh/year
Energy Efficiency Gain	3881.00%	%
Energy Injected to Grid	36,903	KWh/ year
CO2 Emissions Savings	1.,6	Tm CO2/ year

5. COMMUNICATION MEASURES

This programme fulfils all the standards to be considered an implemented good practice co-funding by ERDF. The information and publishing responsibilities can be found on the Annex XII, section 2.1. within the Regulation (EU) No 1303/3013 of the European Parliament and of the Council of 17 December 2013, among which highlight:

- Organizing a major information activity publicizing the launch of the operational programme or programmes.
- Organizing one major information activity a year which promotes the funding, opportunities and the strategies pursued and present the achievements of the operational programme or programmes, including, where relevant, major projects, joint action plans and other projects examples.
- Display the Union emblem at the premises of each managing authority.
- Publishing electronically the list of operations.



La Rinconada
Town Hall

- Giving example of operations, by operational programme, on the single website or on the operational programme's website that is accessible through the single website portal; the examples should be in a widely spoken official language of the Union other than the official language or languages of the Member State concerned.
- Updating information about the operational programme's implementation, including, when appropriate, its main achievements, on the single website or on the operational programme's website that is accessible through the single website portal.

For communication and sensitization measures related with the operation implemented, a total of €128.26 has been invested. This operation has been co-funding by ERDF funds and La Rinconada Town Hall.

We should highlight that in all the communication measures made, the required elements by the normative references were included: The Union emblem, the ERDF co-funding reference, and the slogan "A way of making Europe". Furthermore, these elements not only appear in the communication plaque but also in reports, procurement documents, projects, bills, etc.



1. EU EMBLEM IN THE COMMUNICATION PLAQUE



2. EU EMBLEM IN THE TENDER SPECIFICATIONS



La Rinconada
Town Hall

La Rinconada Town Hall

3. LA RINCONADA TOWN HALL WEBSITE (EUROPEAN Funds)

Link: <https://www.larinconada.es/fondos-europeos/feder/periodo-2014-2020/edusi/operaciones-y-expresiones-de-interes/eficiencia-energetica>

4. LA RINCONADA TOWN HALL WEBSITE (News)

Published on August 25, 2023

Link: <https://www.larinconada.es/noticias/13133/el-pua-se-suma-al-ahorro-energetico-con-la-colocacion-de-placas-fotovoltaicas>

6. FINAL RESULT

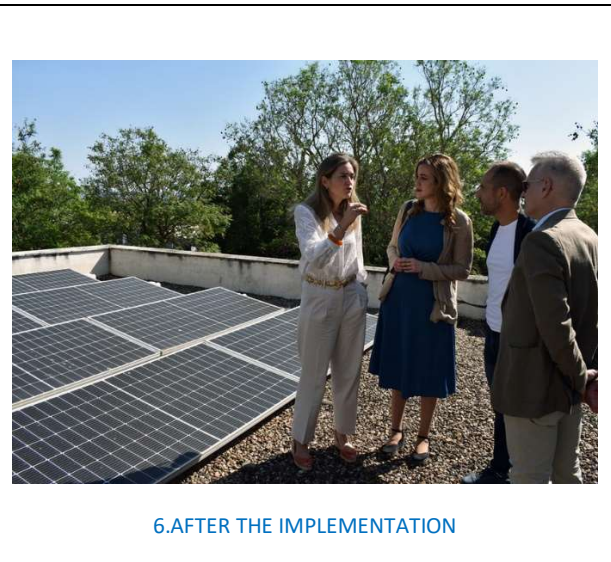



La Rinconada
Town Hall



7. BEFORE THE IMPLEMENTATION

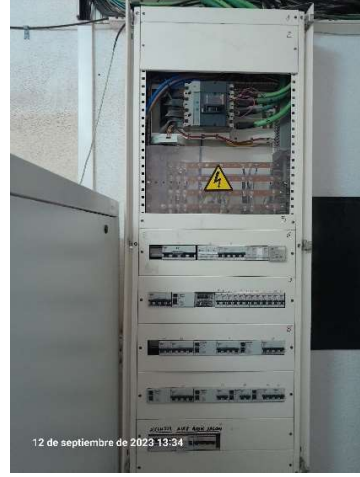

8. AFTER THE IMPLEMENTATION